

General Specifications

Model FLXA21
2-Wire Analyzer

FLEXA
SENCOM

GS 12A01A02-01E

■ General

The model FLXA[®]21 2-Wire Analyzer, one model of FLEXA[®] series, offers single or dual sensor measurement. The modular-designed analyzer offers 4 kinds of measurements – pH/ORP (oxidation-reduction potential), contacting conductivity (SC), inductive conductivity (ISC) or dissolved oxygen (DO) – with the respective sensor module.

For dual sensor measurement, the combination of two same type sensor inputs – pH/ORP and pH/ORP (analog sensor only), SC and SC, and DO and DO – are available with two sensor modules. Dual sensor measurement offers additional functionalities; calculated data function and redundant system.

Variety of calculated data from two measuring parameters is selectable for each measurement. On the redundant system built on two measuring parameters of two sensor inputs, main output parameter is automatically switched over to the second sensor output in case of the main sensor's failure condition.

In addition to conventional analog pH/ORP sensors, the analyzer FLXA21 can be connected to Yokogawa's digital sensor, FU20F pH/ORP SENCOM[®] Sensor.

In the FLXA21 Human Machine Interface (HMI), 2-wire type analyzer FLXA21 offers easy touch screen operation and simple menu structure in 12 languages. Menus of display, execution and setting are displayed in a selected language.

The analyzer FLXA21 automatically recognizes the installed sensor module and prepares the necessary menus for right configuration, even for dual sensor measurement.

For immediate measurement, the FLXA21 offers quick setup functionality. The quick setup screen appears when the analyzer is powered. Only a few setups – date/time, language, basic sensor configurations and output – will start the measurement.

The FLXA21 offers the best accuracy in measurement with temperature compensation functionality and calibration functionality. Sensor diagnostics and sensor wellness indication make measurement reliable. Logbook of events and diagnostic data is a useful information source for maintenance.

For the wide range of industrial environment, the FLXA21 is designed with the enclosure of plastic, stainless steel or stainless steel with corrosion-resistant coating. And, for hazardous location, the FLXA21 has approvals of ATEX, IECEx, FM, CSA and NEPSI.



■ Features

- 4 kinds of measurements; pH/ORP, SC, ISC and DO
- Dual sensor measurement on 2-wire type analyzer; pH/ORP and pH/ORP, SC and SC, and DO and DO
- Calculated data from dual sensor measurement
- Redundant system on dual sensor measurement
- Connection of digital FU20F pH/ORP SENCOM Sensor
- Easy touch screen operation on 2-wire type analyzer
- Simple HMI menu structure in 12 languages
- Quick setup menu for immediate measurement
- Indication of sensor wellness
- Enclosure – plastic, stainless steel or stainless steel with corrosion-resistant coating
- Hazardous location approvals – ATEX, IECEx, FM, CSA and NEPSI

■ General Specifications

1. Basic

■ Measurement Object/Sensor Type

- pH/Oxidation-reduction Potential (pH/ORP) (analog sensor)
- Conductivity (SC)
- Inductive Conductivity (ISC)
- Dissolved Oxygen (DO)
- pH/Oxidation-reduction Potential (pH/ORP) (digital sensor)

Note: The available measurement object depends on a sensor module installed on the analyzer.

■ Analyzer Structure

Module structure

● Composition of Analyzer

One (1) Housing assembly
One (1) or two (2) Sensor modules

● Combination of Sensor Module when two modules are installed

Combinations of two same sensor modules are available;

- pH/ORP and pH/ORP (analog sensor)
- SC and SC
- DO and DO

2. Measurement

2-1. pH/Oxidation-reduction Potential (pH/ORP) with analog sensors

■ Input Specification

Dual high impedance input ($\geq 10^{12} \Omega$)

■ Input Range

pH: -2 to 16 pH
ORP: -1500 to 1500 mV
rH: 0 to 100 rH
Temperature:
Pt1000: -30 to 140 °C
Pt100: -30 to 140 °C
6.8k: -30 to 140 °C
PTC10k: -30 to 140 °C
NTC 8k55: -10 to 120 °C
3k Balco: -30 to 140 °C
PTC500: -30 to 140 °C

■ Output Range

pH: min. span 1 pH
max. span 20 pH
ORP: min. span 100 mV
max. span 3000 mV
rH: min. span 2 rH
max. span 100 rH
Temperature: min. span 25 °C
max. span 170 °C

■ Performance (Accuracy)

(The specifications are expressed with simulated inputs.)

pH
Linearity: ± 0.01 pH
Repeatability: ± 0.01 pH
Accuracy: ± 0.01 pH
ORP
Linearity: ± 1 mV
Repeatability: ± 1 mV
Accuracy: ± 1 mV

Temperature

with Pt1000, 6.8k, PTC10k, NTC 8k55, 3k Balco, PTC500

Linearity: ± 0.3 °C
Repeatability: ± 0.1 °C
Accuracy: ± 0.3 °C

with Pt100

Linearity: ± 0.4 °C
Repeatability: ± 0.1 °C
Accuracy: ± 0.4 °C

2-2. Conductivity (SC)

■ Input Specification

Two or four electrodes measurement with square wave excitation, using max 60m (200ft) cable (WU40/WF10) and cell constants from 0.005 to 50.0 cm^{-1}

■ Input Range

Conductivity:
min.: 0 $\mu\text{S}/\text{cm}$
max.: 200 $\text{mS} \times (\text{Cell constant})$
(over range 2000 mS/cm)

Resistivity:
min.: 0.005 $\text{k}\Omega / (\text{Cell constant})$
max.: 1000 $\text{M}\Omega \times \text{cm}$

Temperature:

Pt1000: -20 to 250 °C
Pt100: -20 to 200 °C
Ni100: -20 to 200 °C
NTC 8k55: -10 to 120 °C
Pb36(JIS NTC 6k): -20 to 120 °C

■ Output Range

Conductivity:
min. 0.01 $\mu\text{S}/\text{cm}$
max. 2000 mS/cm (max 90% zero suppression)
Resistivity:
min. 0.001 $\text{k}\Omega \times \text{cm}$
max. 1000 $\text{M}\Omega \times \text{cm}$ (max 90% zero suppression)
Temperature:
min. span 25 °C
max. span 270 °C

■ Performance (Accuracy)

(The specifications are expressed with simulated inputs.)

Conductivity
2 $\mu\text{S} \times \text{K} \text{cm}^{-1}$ to 200 $\text{mS} \times \text{K} \text{cm}^{-1}$
Accuracy: $\pm 0.5\%$ F.S.
1 $\mu\text{S} \times \text{K} \text{cm}^{-1}$ to 2 $\mu\text{S} \times \text{K} \text{cm}^{-1}$
Accuracy: $\pm 1\%$ F.S.

Resistivity
0.005 $\text{k}\Omega / \text{K} \text{cm}^{-1}$ to 0.5 $\text{M}\Omega / \text{K} \text{cm}^{-1}$
Accuracy: $\pm 0.5\%$ F.S.
0.5 $\text{M}\Omega / \text{K} \text{cm}^{-1}$ to 1 $\text{M}\Omega / \text{K} \text{cm}^{-1}$
Accuracy: $\pm 1\%$ F.S.

Temperature

with Pt1000, Pb36, Ni100
Accuracy: ± 0.3 °C
with Pt100, NTC 8k55
Accuracy: ± 0.4 °C

Temperature compensation

NaCl table: ± 1 %
Matrix: ± 3 %

Step response: 90 % (< 2 decades) in 7 seconds

Note: "F.S." means maximum setting value of analyzer output.

"K" means cell constant.

YOKOGAWA provides conductivity sensors of which cell constants are 0.1 to 10 cm^{-1} .

2-3. Inductive Conductivity (ISC)

■ Input Specification

Compatible with the Yokogawa inductive conductivity ISC40 series with integrated temperature sensor: NTC30k or Pt1000.

■ Input Range

Conductivity: 0 to 2000 mS/cm at 25 °C reference temperature.

Temperature: -20 to 140 °C

Cable length:

max. 60 meters total length of fixed sensor cable + WF10(J) extension cable.

Influence of cable can be adjusted by doing an AIR CAL with the cable connected to a dry cell.

■ Output Range

Conductivity:

min. span: 100 μ S/cm

max. span: 2000 mS/cm (max 90% zero suppression)

Temperature:

min. span 25 °C

max. span 160 °C

■ Performance (Accuracy)

(The specifications are expressed with simulated inputs.)

(Output span is 0-100 μ S/cm or more)

Conductivity:

Linearity: $\pm(0.4 \%F.S. + 0.3 \mu S/cm)$

Repeatability: $\pm(0.4 \%F.S. + 0.3 \mu S/cm)$

Temperature: ± 0.3 °C

Step response: 90 % (< 2 decades) in 8 seconds

Note: "F.S." means maximum setting value of analyzer output.

2-4. Dissolved Oxygen (DO)

■ Input Specification

The FLXA21 accepts output from membrane covered Dissolved Oxygen sensors. These sensors can be Galvanic type, where the sensor generates its own driving voltage or Polarographic type, where the sensor uses external driving voltage from the converter.

The input range is 0 to 50 μ A for Galvanic sensors and 0 to 1 micro A for Polarographic sensors.

For temperature compensation, the FLXA21 accepts Pt1000 (DO30 sensor) and NTC22k elements (OXYFERM and OXYGOLD sensors).

■ Input Range

DO30 sensor:

Dissolved Oxygen: 0 to 50 mg/l (ppm)

Temperature: -20 to 150 °C

Note: Process temperature for DO30 is 0 to 40 °C

Hamilton sensors:

Oxyferm:

Measurement range: 10 ppb to 40 ppm

Temperature range: 0 to 130 °C

Oxygold G:

Measurement range: 2 ppb to 40 ppm

Temperature range: 0 to 130 °C

Oxygold B:

Measurement range: 8 ppb to 40 ppm

Temperature range: 0 to 100 °C

■ Output Range

DO concentration:

mg/l (ppm):

min.: 1 mg/l (ppm)

max.: 50 mg/l (ppm)

ppb:

min.: 1 ppb

max.: 9999 ppb

% saturation:

min.: 10 %

max.: 600 %

Temperature:

min. span 25 °C

max. span 170 °C

■ Performance (Accuracy)

(The specifications are expressed with simulated inputs.)

Performance in ppm mode:

Linearity: ± 0.05 ppm or $\pm 0.8\%$ F.S., whichever is greater

Repeatability: ± 0.05 ppm or $\pm 0.8\%$ F.S., whichever is greater

Accuracy: ± 0.05 ppm or $\pm 0.8\%$ F.S., whichever is greater

Performance in ppb mode:

Linearity: ± 1 ppb or $\pm 0.8\%$ F.S., whichever is greater

Repeatability: ± 1 ppb or $\pm 0.8\%$ F.S., whichever is greater

Accuracy: ± 1 ppb or $\pm 0.8\%$ F.S., whichever is greater

Temperature

Linearity: ± 0.3 °C

Repeatability: ± 0.1 °C

Accuracy: ± 0.3 °C

Note: "F.S." means maximum setting value of analyzer output.

2-5. pH/Oxidation-reduction Potential (pH/ORP) with digital sensor, FU20F pH/ORP SENCOR Sensor

■ Input Specification

Bi-directional digital communication (RS-485) between FU20F and FLXA21

■ Input Range (depending on FU20F)

pH: 0 to 14 pH

ORP: -1500 to 1500 mV

rH: 0 to 100 rH

Temperature: -10 to 105 °C

■ Output Range

pH: min. span 1 pH

max. span 20 pH

ORP: min. span 100 mV

max. span 3000 mV

rH: min. span 2 rH

max. span 100 rH

Temperature: min. span 25 °C

max. span 170 °C

3. Electrical

■ Output Signal

General: One output of 4-20 mA DC
 Note: Tolerance: ± 0.02 mA
 Bi-directional HART digital communication,
 superimposed on mA (4-20mA) signal

Output function:

Linear or Non-linear (21-step table)

Burn out function: (NAMUR 43 except ISC)

Without HART/PH201G:

Down: 3.6 mA

(signal: 3.8 to 20.5 mA for pH/ORP, SC
 and DO)

(signal: 3.9 to 20.5 mA for ISC)

Up: 22mA

With HART/PH201G:

Down: 3.6 mA for pH/ORP, SC and DO

Down: 3.9 mA for ISC

(signal: 3.8 to 20.5 mA for pH/ORP, SC
 and DO)

(signal: 3.9 to 20.5 mA for ISC)

Up: 22mA

■ Power Supply

Nominal 24 V DC loop powered system

One (1) Sensor module (1 input):

16 to 40V DC (for pH/ORP (analog
 sensor), SC and DO)

17 to 40V DC (for ISC)

21 to 40V DC (for pH/ORP SENCOM
 sensor)

Two (2) Sensor modules (2 inputs):

22.8 to 40V DC (for pH/ORP (analog sensor),
 SC and DO)

Note: When the FLXA21 is used in the multi-drop mode of HART communication, the output signal is changed from 12.5 mA DC to 4 mA DC just after the power is turned on. Enough power supply for the instruments is to be provided.

● Maximum Load Resistance

pH/ORP (analog sensor), SC and DO:

Refer to the Figure 1.

ISC and pH/ORP SENCOM sensor:

Refer to the Figure 2.

■ Display

LCD with a touch screen:

Black/White: 213 x 160 pixels

Contrast adjustment available on the touch screen

Message language:

12 (English, Chinese, Czech, French,
 German, Italian, Japanese, Korean,
 Polish, Portuguese, Russian and Spanish)
 One analyzer has all 12 languages.

Note: Description for a selection of language and language names are written in English.

Note: Only English alphabet and numeric are available for a tag number, an additional description for each value on the display screen and passwords.

Note: Only for message language on the screen, 12 languages are provided.

4. Mechanical and others

■ Housing

Case:

- Plastic (Polycarbonate)
- Stainless steel without painting
- Stainless steel with epoxy coating
- Stainless steel with urethane coating
- Stainless steel + high anti-corrosion coating

Case color and finish:

Color: Silver gray (equivalent to Munsell
 3.2PB7.4/1.2)
 (for plastic case, stainless steel cases
 with coating)

Finish: Electropolishing (for stainless steel
 case without painting)

Window: Polycarbonate (flexible)

Window frame for stainless steel cases:

Polycarbonate, color: silver gray
 (equivalent to Munsell 3.2PB7.4/1.2)

Protection: IP66 (except Canada), Type 4X (except
 Canada), Type 3S/4X (Canada)

■ Plate

Main name plate: inside case cover

Regulation plate:

on the case outside

■ Cable and Terminal

Cable size:

Outer diameter:

6 to 12 mm (suitable for M20 cable gland)

3.4 to 7 mm (grounding cable for plastic case)

Terminal screw size: M4

torque of screw up: 1.2 N·m

Wire terminal:

Pin terminal, ring terminal and spade
 terminal can be used for analyzer's power
 supply terminals and sensor terminals.

For the grounding terminal on the stainless
 steel case, ring terminal should be used.

Pin terminal: pin diameter: max. 1.9 mm

Ring and spade terminal: width: max. 7.8 mm

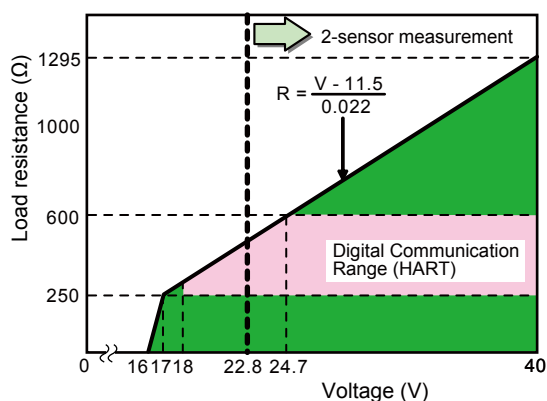

Figure 1 Supply Voltage and Load Resistance for pH/ORP (analog sensor), SC and DO

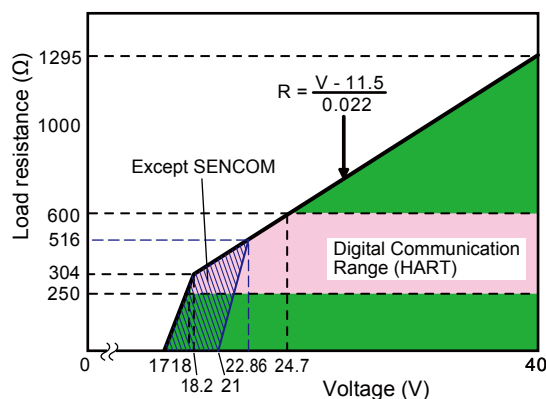

Figure 2 Supply Voltage and Load Resistance for ISC and pH/ORP SENCOM sensor

■ Cable Entry

Plastic case:

- 1-Sensor measurement:
 - 3 holes,
 - M20 cable gland x 3 pcs,
 - Sleeve x 1 pc (for grounding cable line)

- 2-Sensor measurement:
 - 4 holes,
 - M20 cable gland x 4 pcs,
 - Sleeve x 1 pc (for grounding cable line)

Stainless steel case:

- 3 holes,
- M20 cable gland x 3 pcs
- Close up plug x 1 pc

Note: Cable gland and plug are delivered with an analyzer, but not assembled into the analyzer.

■ Mounting

Mounting hardware (option):

- Universal mounting kit (Note)
- Pipe and wall mounting hardware
- Panel mounting hardware

Note: This kit contains the pipe and wall mounting hardware and the panel mounting hardware.

Hood (option):

- Stainless steel
- Stainless steel with urethane coating
- Stainless steel with epoxy coating

■ Stainless Steel Tag Plate

When the additional code "/SCT" with a tag number is specified, the tag plate on which the tag number is inscribed is delivered with the analyzer.

Tag plate is hanging type.

■ Conduit Adapter

Using optional adapter

- G1/2 (quantity: 4)
- 1/2NPT (quantity: 4)
- M20 x 1.5 (quantity: 4)

These conduit adapters are delivered with an analyzer, but not assembled into the analyzer.

■ Size of Housing Case

Plastic: 144 (W) x 144 (H) x 151 (D) mm (without cable gland)

Stainless steel case:
165 (W) x 165 (H) x 160 (D) mm (without cable gland)

■ Weight

Approx. 1 kg (Plastic housing)

Approx. 2 kg (Stainless steel housing)

■ Ambient Operating Temperature

-20 to +55 °C

■ Storage Temperature

-30 to +70 °C

■ Humidity

10 to 90% RH at 40°C (Non-condensing)

■ Document

Following documents are delivered with an analyzer;

Paper copy:

- Start-up Manual
written in English
- Safety Precautions
written in English

CD-ROM:

- Start-up Manual
written in English
- User's Manual
written in English

Safety Regulations Manual
for European region
written in 25 languages

General Specifications
written in English

Technical Information
for HART Communication
written in English

User Setting Table
of 5 kinds of measurement/sensor type
written in English

■ Regulatory Compliance

Safety: UL 61010-1
UL 61010-2-030
CAN/CSA C22.2 No.61010-1
CAN/CSA-C22.2 No.61010-2-030
EN 61010-1
EN 61010-2-030

EMC: EN 61326-1 Class A, Table 2 (For use in industrial locations)
EN 61326-2-3
AS/NZS CISPR11
RCM: EN 55011 Class A, Group 1
Korea Electromagnetic Conformity Standard Class A 한국 전자파적합성 기준

Installation altitude: 2000 m or less

Category based on IEC 61010: I (Note 1)

Pollution degree based on IEC 61010: 2 (Note 2)

Note 1: Installation category, called over-voltage category, specifies impulse withstand voltage.

Equipment with "Category I" (ex. two wire transmitter) is used for connection to circuits in which measures are taken to limit transient over-voltages to an appropriately low level.

Note 2: Pollution degree indicates the degree of existence of solid, liquid, gas or other inclusions which may reduce dielectric strength. Degree 2 is the normal indoor environment.

Intrinsic safety and nonincendive (suffix code Type : -CB, -CD, -DD):

ATEX Intrinsic safety approval

Applicable standard

Explosive Atmospheres
EN 60079-0:2012/A11: 2013 Equipment -
General requirements

EN 60079-11:2012 Equipment protection by
Intrinsic safety "i"

Type of protection

II 1 G Ex ia IIC T4 Ga

Group: II

Category: 1 G

T4: for ambient temperature: -20 to 55°C

Atmosphere pressure: 80kPa
(0.8bar) to 110kPa (1.1bar)

IECEx Intrinsic safety approval

Applicable standard

IEC 60079-0: 2011 Part 0: Equipment -
General requirements

IEC 60079-11: 2011 Part 11: Equipment
protection by Intrinsic safety "i"

Type of protection

Ex ia IIC T4 Ga

T4: for ambient temperature: -20 to 55°C

Atmosphere pressure: 80kPa
(0.8bar) to 110kPa (1.1bar)

FM Intrinsic safety and nonincendive approval

Applicable standard

- Class-3600: 2011 Approval Standard for Electric Equipment for use in Hazardous (Classified) Locations General Requirement
- Class-3610: 2010 Approval Standard for Intrinsically Safe Apparatus and Associated Apparatus for Use in Class I, II, and III, Division 1, Hazardous (Classified) Locations
- Class-3611: 2004 Nonincendive Electrical Equipment for Use in Class I and II, Division 2 and Class III, Divisions 1 and 2, Hazardous (Classified) Locations
- Class-3810: 2005 Electrical Equipment for Measurement, Control and Laboratory Use
- ANSI/NEMA 250:2014 Enclosures for Electrical Equipment (1000 Volts Maximum)
- ANSI/ISA 60079-0 2013 Part 0: General Requirements
- ANSI/ISA 60079-11 2014 Part 11: Equipment protection by intrinsic safety "i"

Type of protection

- Class I, Division 1, Groups A, B, C and D (Intrinsically Safe)
- Class I, Division 2, Groups A, B, C and D (Nonincendive)
- Class I, Zone 0, Group IIC, in Hazardous (Classified) Locations (Intrinsically Safe AEx ia IIC)
- Class I, Zone 2, Group IIC, in Hazardous (Classified) Locations (Nonincendive)
- For all protection type,
T4: for ambient temperature: -20 to 55°C
Atmosphere pressure: 80 kPa (0.8 bar) to 110 kPa (1.1 bar)

CSA Intrinsic safety and nonincendive approval

Applicable standard

- CAN/CSA C22.2 No. 94-M1991 Special Purpose Enclosures
- CAN/CSA C22.2 No. 157-2 Intrinsically Safe and Non-incendive Equipment for Use in Hazardous Locations
- C22.2 No213-M1987 Non-incendive Electrical Equipment for Use in Class I, Division 2 Hazardous Locations
- CAN/CSA-E60079-0-07 Electrical apparatus for explosive gas atmospheres - Part 0: General requirements
- CAN/CSA-E60079-11-02 Electrical apparatus for explosive gas atmospheres - Part 11: Intrinsic safety "i"

Type of protection (C22.2)

Class I, Division 1, Groups A, B, C and D (Intrinsically Safe)

Class I, Division 2, Groups A, B, C and D (Nonincendive)

For all protection type,

T4: for ambient temperature: -20 to 55°C

Atmosphere pressure: 80 kPa (0.8 bar) to 110 kPa (1.1 bar)

Ambient Humidity: 0 to 100% (No condensation)

Type of protection (E60079)

Ex ia IIC T4

T4: for ambient temperature: -20 to 55°C

Atmosphere pressure: 80 kPa (0.8 bar) to 110 kPa (1.1 bar)

Ambient Humidity: 0 to 100% (No condensation)

NEPSI Intrinsic safety approval

Applicable Standard

- GB 3836.1-2010 Explosive atmospheres- Part 1: Equipment - General requirements
- GB 3836.4-2010 Explosive atmospheres- Part 4: Equipment protection by intrinsic safety "i"
- GB 3836.20-2010 Explosive atmospheres- Part 20: Equipment with equipment protection level (EPL) Ga

Type of protection

Ex ia IIC T4 Ga

T4: for ambient temperature: -20°C to 55°C

Atmosphere pressure: 80kPa (0.8bar) to 110kPa (1.1bar)

Electrical Parameters (Ex ia)

Each housing assembly (base module) and each sensor module are respectively certificated. Input parameters of sensor module meet output parameters of housing assembly.

Housing assembly

Input parameters	Supply and output circuit (terminals + and -): $U_i, V_{max} = 30\text{ V}$ $I_i, I_{max} = 100\text{ mA}$ $P_i, P_{max} = 0.75\text{ W}$ $C_i = 13\text{ nF}$ $L_i = 0\text{ mH}$ (Linear source)
Output parameters	Measuring module input circuit (CN2 or CN3 on Back board) $U_o, V_t, V_{oc} = 13.65\text{ V}$ $I_o, I_t, I_{sc} = 50\text{ mA}$ $P_o = 0.372\text{ W}$ $C_o, C_a = 80\text{ nF}$ $L_o, L_a = 7.7\text{ mH}$

pH/ORP module, SC module, and DO module

Input parameters	$U_i, V_{max} = 13.92\text{ V}$ $I_i, I_{max} = 50\text{ mA}$ $P_i, P_{max} = 0.374\text{ W}$ $C_i = 40\text{ nF}$ $L_i = 2.9\text{ mH}$
Output parameters	Sensor input circuit (pH: terminals 11 through 19, SC: terminals 11 through 16, DO: terminals 11 through 18) $U_o, V_t, V_{oc} = 11.76\text{ V}$ $I_o, I_t, I_{sc} = 116.5\text{ mA}$ $P_o = 0.3424\text{ W}$ $C_o, C_a = 100\text{ nF}$ $L_o, L_a = 1.7\text{ mH}$

ISC module

Input parameters	$U_i, V_{max} = 13.92\text{ V}$ $I_i, I_{max} = 50\text{ mA}$ $P_i, P_{max} = 0.374\text{ W}$ $C_i = 40\text{ nF}$ $L_i = 7.7\text{ mH}$
Output parameters	Sensor input circuit (terminals 11 through 17) $U_o, V_t, V_{oc} = 11.76\text{ V}$ $I_o, I_t, I_{sc} = 60.6\text{ mA}$ $P_o = 0.178\text{ W}$ $C_o, C_a = 100\text{ nF}$ $L_o, L_a = 8\text{ mH}$

SENCOM Sensor module

Input parameters	$U_i, V_{max} = 13.92\text{ V}$ $I_i, I_{max} = 50\text{ mA}$ $P_i, P_{max} = 0.374\text{ W}$ $C_i = 40\text{ nF}$ $L_i = 7.2\text{ mH}$
Output parameters	Sensor input circuit (terminals 82, 83, 84, 86 and 87) $U_o, V_t, V_{oc} = 5.36\text{ V}$ $I_o, I_t, I_{sc} = 106.16\text{ mA}$ $P_o = 0.1423\text{ W}$ $C_o, C_a = 31\text{ }\mu\text{F}$ $L_o, L_a = 0.45\text{ mH}$

ATEX and IECEx Control Drawing (for 4-20mA type)

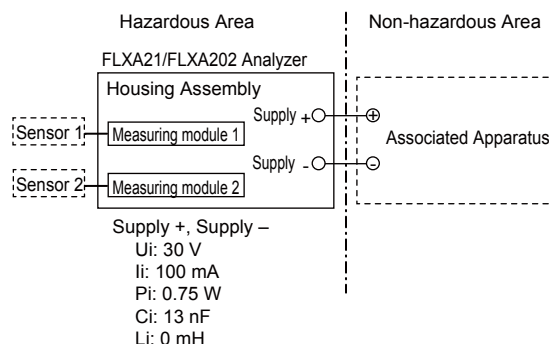

Measuring Module 1, 2

	Type of Measuring Module		
	pH, SC, DO	ISC	SENCOM
Uo	11.76 V	11.76 V	5.36 V
Io	116.5 mA	60.6 mA	106.16 mA
Po	0.3424 W	0.178 W	0.1423 W
Co	100 nF	100 nF	31 μF
Lo	1.7 mH	8 mH	0.45 mH

Specific Conditions of Use

- When the enclosure of FLXA21/202 Analyzer is made of aluminum alloy, and when it is used in an explosive atmosphere requiring equipment of Category 1 G or EPL Ga, the Analyzer must be installed in such a way that, even in the event of rare incidents, an ignition source due to impact friction sparks is excluded.
- Precautions shall be taken to minimize the risk from electrostatic discharge of non-metallic parts of the enclosure or painted parts of the metallic enclosure.

Notes:

1. The associated apparatus must be a linear source.
2. Measuring Module 2 is not necessarily installed. As for ISC module and SENCOM module, only one module is permitted to be installed at a time.
3. Sensor 1 and Sensor 2 may be simple apparatus or intrinsically safe apparatus.
4. WARNING – POTENTIAL ELECTROSTATIC CHARGING HAZARD – SEE USER'S MANUAL

FM Control Drawing (for 4-20mA type)

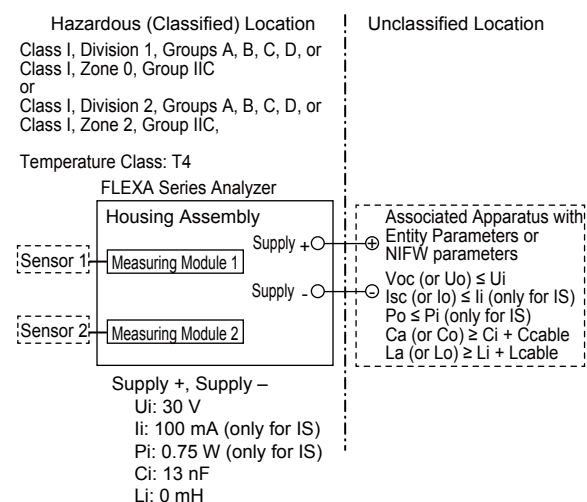

Measuring Module 1, 2

	Type of Measuring Module		
	pH, SC, DO	ISC	SENCOM
Uo	11.76 V	11.76 V	5.36 V
Io	116.5 mA	60.6 mA	106.16 mA
Po	0.3424 W	0.178 W	0.1423 W
Co	100 nF	100 nF	31 μ F
Lo	1.7 mH	8 mH	0.45 mH

Specific Conditions of Use

- Precautions shall be taken to minimize the risk from electrostatic discharge of non-metallic parts and painted parts of the enclosure. When the equipment used in hazardous locations, avoid any action which generate electrostatic discharge such as rubbing with a dry cloth.
- In the case where the enclosure of the analyzer is made of Aluminum, if it is mounted in ZONE 0, it must be installed such, that even in the event of rare incidents, ignition sources due to impact and friction sparks are excluded.

Notes:

1. This drawing replaces the former control drawing IKE039-A12.
2. No revision to this drawing without prior approval of FM.
3. Installation must be in accordance with the National Electric Code (NFPA70), ANSI/ISA RP12.06.01 and relevant local codes.
4. The associated apparatus must be a linear source which is FM-approved.
5. Control equipment connected to the associated apparatus must not use or generate more than 250 V a.c. r.m.s or d.c.
6. The control drawing of the associated apparatus must be followed when installing the equipment.
7. Measuring Module 2 may not be installed. As for ISC module and SENCOM module, only one module is permitted to be installed at a time.
8. For Division 1 / Zone 0 installation, Sensor 1 and Sensor 2 may be simple apparatus, or intrinsically safe apparatus with the following entity parameters. For Division 2 / Zone 2 installation, they may be equipment suitable for Division 2 / Zone 2, or simple apparatus, or nonincendive field wiring apparatus with the following nonincendive field wiring parameters.
 - U_i (or V_{max}) $\geq U_o$
 - I_i (or I_{max}) $\geq I_o$
 - $P_i \geq P_o$
 - $C_i \leq C_o - C_{cable}$
 - $L_i \leq L_o - L_{cable}$
9. For Division 2 / Zone 2 installation, general-purpose power supply may be used if a wiring method suitable for Division 2, but other than nonincendive field wiring, is taken.
10. WARNING – POTENTIAL ELECTROSTATIC CHARGING HAZARD -WHEN THE EQUIPMENT USED IN HAZARDOUS LOCATIONS, AVOID ANY ACTION WHICH GENERATE ELECTROSTATIC DISCHARGE SUCH AS RUBBING WITH A DRY CLOTH.

11. WARNING – IN THE CASE WHERE THE ENCLOSURE OF THE ANALYZER IS MADE OF ALUMINUM, IF IT IS MOUNTED IN ZONE 0, IT MUST BE INSTALLED SUCH, THAT EVEN IN THE EVENT OF RARE INCIDENTS, IGNITION SOURCES DUE TO IMPACT AND FRICTION SPARKS ARE EXCLUDED
12. WARNING – SUBSTITUTION OF COMPONENTS MAY IMPAIR INTRINSIC SAFETY AND SUITABILITY FOR DIVISION 2 / ZONE 2.

CSA

Control Drawing (for 4-20mA type)

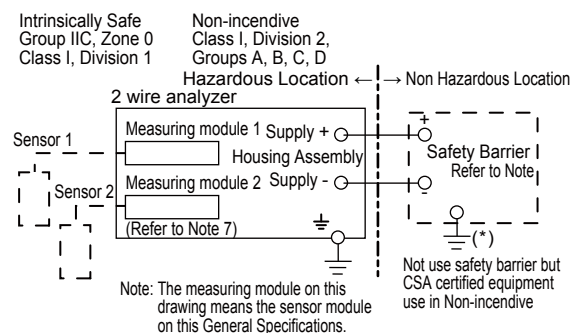

Electrical parameters (Intrinsically safe)

Housing Assembly

Supply and output circuit (terminals + and -)

$U_i(V_{max})=30V$, $I_i(I_{max})=100mA$,

$P_i(P_{max})=0.75W$, $C_i=13nF$, $L_i=0mH$

Measuring module input circuit (CN2 or CN3 on Back board)

$U_o(V_t, V_{oc})=13.65V$, $I_o(I_t, I_{sc})=50mA$,

$P_o=0.372W$, $C_o(C_a)=80nF$,

$L_o(L_a)=7.7mH$

pH module, SC module and DO module

$U_i(V_{max})=13.92V$, $I_i(I_{max})=50mA$,

$P_i(P_{max})=0.374W$, $C_i=40nF$, $L_i=2.9mH$

Sensor input circuit (terminals 11 through 19)

$U_o(V_t, V_{oc})=11.76V$, $I_o(I_t, I_{sc})=116.5mA$,

$P_o=0.3424W$, $C_o(C_a)=100nF$,

$L_o(L_a)=1.7mH$

ISC module

$U_i(V_{max})=13.92V$, $I_i(I_{max})=50mA$,

$P_i(P_{max})=0.374W$, $C_i=40nF$, $L_i=7.7mH$

Sensor input circuit (terminals 11 through 17)

$U_o(V_t, V_{oc})=11.76V$, $I_o(I_t, I_{sc})=60.6mA$,

$P_o=0.178W$, $C_o(C_a)=100nF$,

$L_o(L_a)=8mH$

Installation requirements between housing assembly and safety barrier

$U_o \leq U_i$ $I_o \leq I_i$ $P_o \leq P_i$ $C_o \geq C_i + C_{cable}$ $L_o \geq L_i + L_{cable}$

$V_{oc} \leq V_{max}$ $I_{sc} \leq I_{max}$ $C_a \geq C_i + C_{cable}$ $L_a \geq L_i + L_{cable}$

U_o , I_o , P_o , C_o , L_o , V_{oc} , I_{sc} , C_a and L_a are parameters of barrier.

Electrical Parameters (Nonincendive)

Housing Assembly

Supply and output circuit (terminals + and -)

$U_i(V_{max})=30V$, $C_i=13nF$, $L_i=0mH$

Measuring module input circuit (CN2 or CN3 on Back board)

$U_o(V_t, V_{oc})=13.65V$, $I_o(I_t, I_{sc})=50mA$,

$C_o(C_a)=80nF$, $L_o(L_a)=7.7mH$

pH module, SC module and DO module

$U_i(V_{max})=13.92V$, $C_i=40nF$, $L_i=2.9mH$

Sensor input circuit (terminals 11 through 19)
 $U_o(V_t, V_{oc})=11.76V$, $I_o(I_t, I_{sc})=116.5mA$,
 $C_o(C_a)=4\mu F$, $L_o(L_a)=4.5mH$

ISC module

$U_i(V_{max})=13.92V$, $C_i=40nF$, $L_i=7.7mH$

Sensor input circuit (terminals 11 through 17)

$U_o(V_t, V_{oc})=11.76V$, $I_o(I_t, I_{sc})=60.6mA$,
 $C_o(C_a)=4\mu F$, $L_o(L_a)=19mH$

Note for Intrinsically Safe Installation:

- 1: In any safety barrier used, the output current must be limited by a resistor "R" such that $I_o=U_o/R$ or $I_{sc}=V_{oc}/R$.
- 2: The safety barrier must be CSA certified.
- 3: Input voltage of the safety barrier must be less than 250Vrms/Vdc
- 4: When using non isolation barrier connect (*) to IS earthing system.
- 5: pH and SC Sensor(s) are of a passive type to be regarded as 'simple apparatus' same as 06ATEX0218X, 06ATEX0219, IECEx KEM 06.0052X, FM3028779, 06ATEX0220X, 06ATEX0221, IECEx KEM 06.0053X or the one individually certified with relevant parameters.
- 6: ISC Sensor(s) are ISC40S of 00ATEX1067X or the one individually certified with relevant parameters.
- 7: DO Sensor(s) are of a passive type to be regarded as 'simple apparatus' or the one individually certified with relevant parameters.
- 8: Measuring module 2 may not be mounted. As for ISC module, only one can be mounted.
- 9: Installation should be in accordance with Canadian Electrical Code Part I and Local Electrical Code.
- 10: Do not alter drawing without authorization from CSA.

Note for Nonincendive Installation:

- 1: The parameter for sensor input circuit must be taken into account when installed.
- 2: Installation should be in accordance with Canadian Electrical Code Part I and Local Electrical Code.
- 3: Do not alter drawing without authorization from CSA.

NEPSI

Control Drawing (for 4-20mA type)

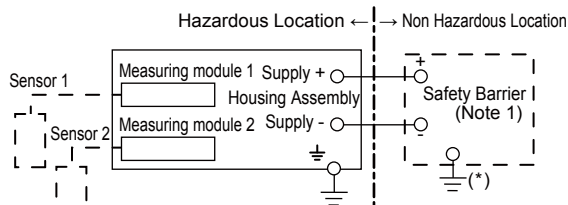

Electrical data are as follows;

Maximum Voltage (U_i) = 30V
 Maximum Current (I_i) = 100mA
 Maximum Power (P_i) = 0.75W
 Internal Capacitance (C_i) = 13nF
 Internal Inductance (L_i) = 0mH

Note 1: The output current must be limited by a resistor "R" such that $I_{maxout}=U_z/R$ (linear source).

Note 2: Safety barrier certified by NEPSI should be used.

Note 3: When using non isolation barrier, connect (*) to IS earthing system.

Note 4: Measuring module 2 is installed when required. When measuring inductive conductivity, only one module can be installed.

5. Digital Communication

■ Kind of Digital Communication

- HART or PH201G dedicated distributor
 Note: Only one kind of digital communication is available for one analyzer.

■ Output Value Parameter (HART)

Four value parameters (measured values) are available for one digital communication.

- For 1-sensor measurement, these parameters are measured values.
- For 2-sensor measurement, refer to the next item.

■ Digital Communication of 2-Sensor Measurement (HART)

Even when two sensor modules are installed, only one digital communication is available for 2-sensor measurement.

Four value parameters can be selected from the followings;

- Measured values of two sensors
- Calculated data of 2-sensor measurement
- Redundant system output

■ Specific Contact Output with dedicated distributor, model PH201G (Style B)

The distributor, model PH201G, is designed to connect with the 2-Wire Analyzer.

This distributor supplies drive power to the analyzer and receives simultaneously 4-20 mA DC signal from the analyzer.

This signal is converted to 1-5 V DC signal in the distributor.

This distributor also receives digital signals superimposed on the 4-20 mA DC signal, and provides contact outputs

Input/Output signal:

- Number of available drive/signal point: 1
- Output signal: 1-5 V DC (2 points) (Note)
- Load resistance: 2 kΩ or less (1-5 V DC output)
- Isolation system: Loop isolation type
- Note: Two output signals for one analyzer's analog output are provided. Two 1-5 V DC output signals are same.

Contact output:

- Contact rating:
 250 V AC, maximum 100 VA
 220 V DC, maximum 50 VA
- Hold contact output:
 NC contact, normally energized
 Contact closes when power is off or during Hold situation.
- Fail contact output:
 NC contact, normally energized
 Contact closes when power is off or during Fail/Warning conditions.
- Wash contact output:
 NO contact
 Contact closes during wash cycles.

Regulatory Compliance

Korea Electromagnetic Conformity Standard Class A
 한국 전자과적합성 기준

6. Model & Suffix Codes

Model	Suffix code	Option code	Description
FLXA21	2-Wire Analyzer
Power supply	-D	Always -D
Housing	-P -S -J -E -W	Plastic Stainless steel Stainless steel + urethane coating Stainless steel + epoxy coating Stainless steel + high anti-corrosion coating (Note 17)
Display	-D	Anti-glare LCD
Type	-AB -AD -AG -AQ -AR -CB -CD -EA -EG -EQ -ER -DD	General purpose for CE, RCM General purpose for CSA General purpose for KC General purpose for EAC with PA (Note 11) General purpose for EAC (Note 12) IS for ATEX, IEC Ex (Note 9) IS for FM, (CSA(pending)) (Note 15) IS for FM, CSA, NEPSI (Note 5) IS for KOSHA (Note 10) IS for EACEx with PA (Note 13) IS for EACEx (Note 14) NI for FM, (CSA(pending)) (Note 16)
1st input	-P1 -C1 -C5 -D1 -S1	pH/ORP (Note 6) Conductivity (SC) Inductive conductivity (ISC) Dissolved oxygen (DO) pH/ORP (SENCOM sensor) (Note 7)
2nd input (Note 1)	-NN -P1 -C1 -D1	Without input pH/ORP (Note 6) Conductivity (SC) Dissolved oxygen (DO)
Output (Note 8)	-A	4-20 mA + HART
—	-N	Always -N
Language set (Note 2)	-LA	English and 11 languages
Country (Note 3)	-N -J	Global except Japan Japan
—	-NN	Always -NN
Option	Mounting hardware Hood Tag plate Conduit adapter	/UM /U /PM /H6 /H7 /H8 /SCT /CB4 /CD4 /CF4	Universal mounting kit (Note 4) Pipe and wall mounting hardware Panel mounting hardware Hood, stainless steel Hood, stainless steel + urethane coating Hood, stainless steel + epoxy coating Stainless steel tag plate Conduit adapter (G1/2 x 4 pcs) Conduit adapter (1/2NPT x 4 pcs) Conduit adapter (M20 x 1.5 x 4 pcs)

Notes:

- When a 2nd input is selected, only the same kind of the 1st input is available.
For example, when a 1st input is “-P1”, the 2nd input must be the same “-P1”.
The combination of ISC and ISC is not available. And, the combination of SENCOM sensor and SENCOM sensor is not available, either.
- These languages are message languages on the analyzer’s display.
One analyzer has English and 11 languages.
All languages are as follows: English, Chinese, Czech, French, German, Italian, Japanese, Korean, Polish, Portuguese, Russian and Spanish.
- When an analyzer is used in Japan, it must meet the Japanese Measurement Law.
Only SI units must be used on the analyzer and its documents in Japan.
- The universal mounting kit contains the pipe and wall mounting hardware (/U) and the panel mounting hardware (/PM).
- The type “-EA” is intrinsic safety of CSA and NEPSI, and non-incendive of CSA. Temperature classes are T4. The type “-EA” cannot be used with SENCOM sensor.
- This input is to be come from an analog pH/ORP sensor.
- When the analyzer is connected with the digital sensor, FU20F pH/ORP SENCOM Sensor, only the following model is available;
2nd input: Without input (-NN)
- The FLXA21 has other output types of “FOUNDATION Fieldbus” communication (suffix code: -F) and “PROFIBUS PA” communication (suffix code: -P). Refer to GS 12A01A02-71E and GS 12A01A02-72E.

- 9: The type “-CB” intrinsic safety type of ATEX and IECEx can be used with SENCOM sensor. Temperature class is T4.
 10: The type “-EG” intrinsic safety type of KOSHA for Korea. Temperature class is T4.
 11: The type “-AQ” is General purpose type of EAC with Pattan Approval for Russia.
 12: The type “-AR” is General purpose type of EAC for Kazakhstan and Belarus.
 13: The type “-EQ” intrinsic safety type of EAC with Pattan Approval for Russia. Temperature class is T4.
 14: The type “-ER” intrinsic safety type of EAC for Kazakhstan and Belarus. Temperature class is T4.
 15: The type “-CD” intrinsic safety type for FM. Temperature class is T4.
 16: The type “-DD” nonincendive type for FM. Temperature class is T4.
 17: The housing with stainless steel + high anti-corrosion coating is not available for the type “-EA”.

■ Dimensions and Mounting

Plastic Housing

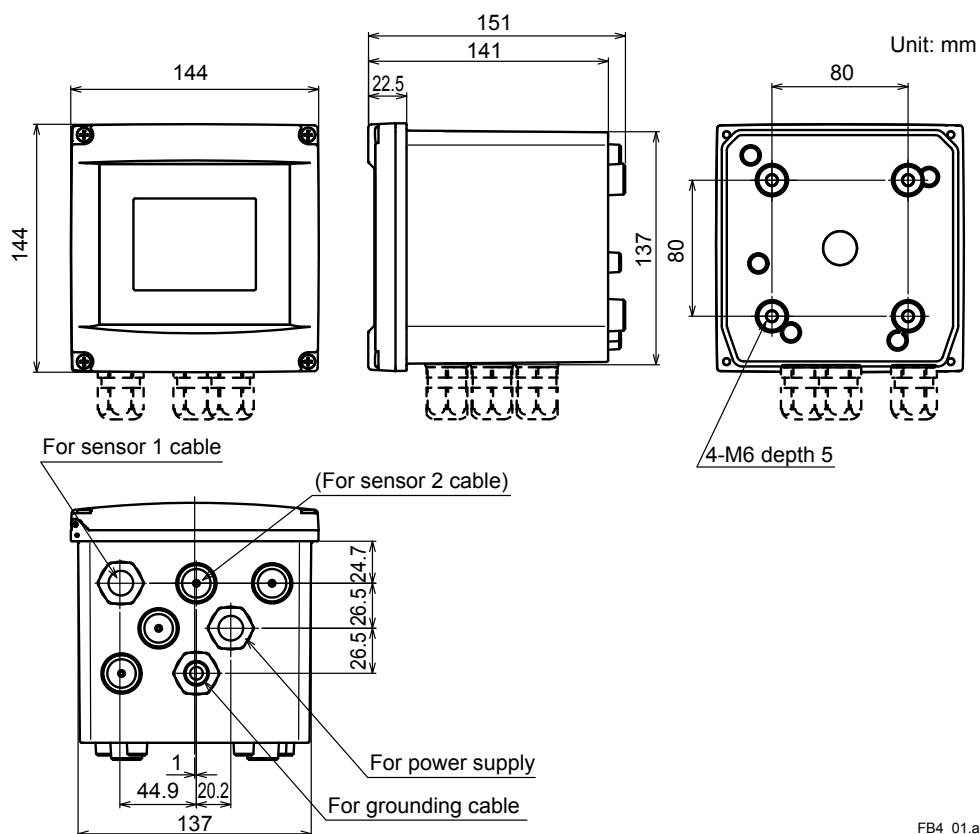

FB4_01.ai

Conduit Adapter (Option code: □/CB4, □/CD4, □/CF4)

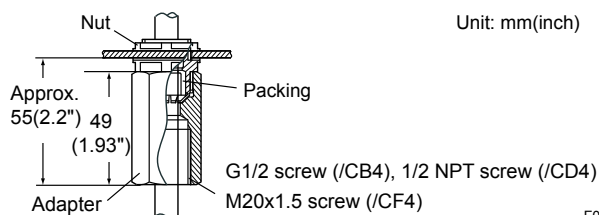

F0204.ai

(Note) The universal mounting kit (/UM) contains the pipe and wall mounting hardware (/U) and the panel mounting hardware (/PM).

Panel mounting hardware (Option code: □/PM, □/UM)

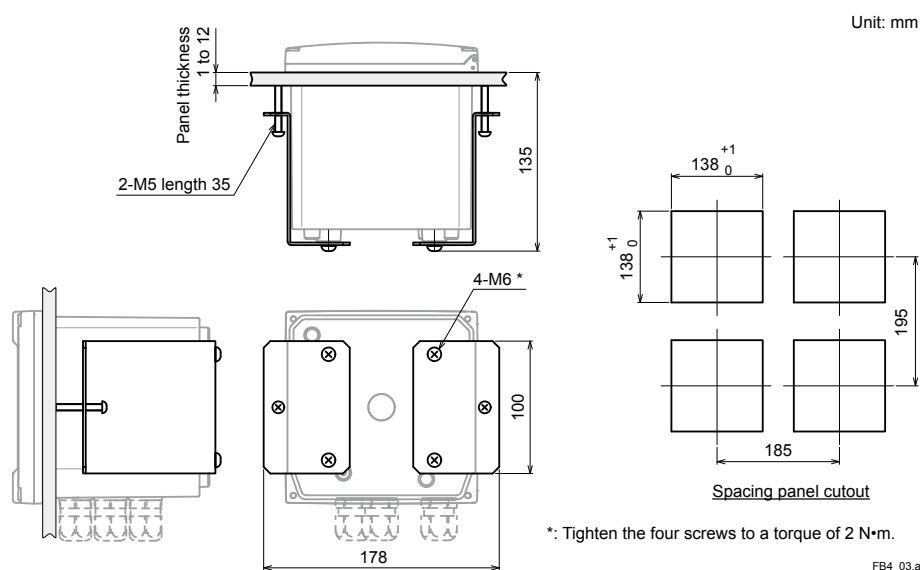

Wall mounting hardware (Option code: □/U, □/UM)

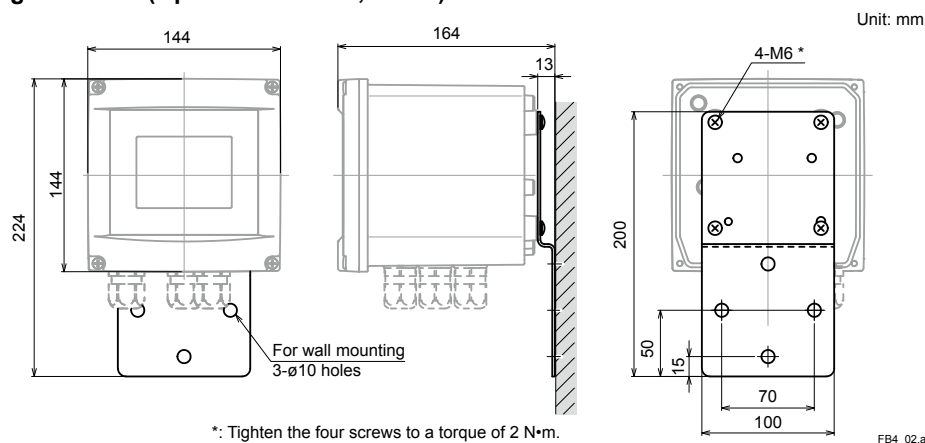

Note: The wall on which the analyzer is mounted should be strong enough to bear the weight of more than 8 kg.

Pipe mounting hardware (Option code: □/U, □/UM)

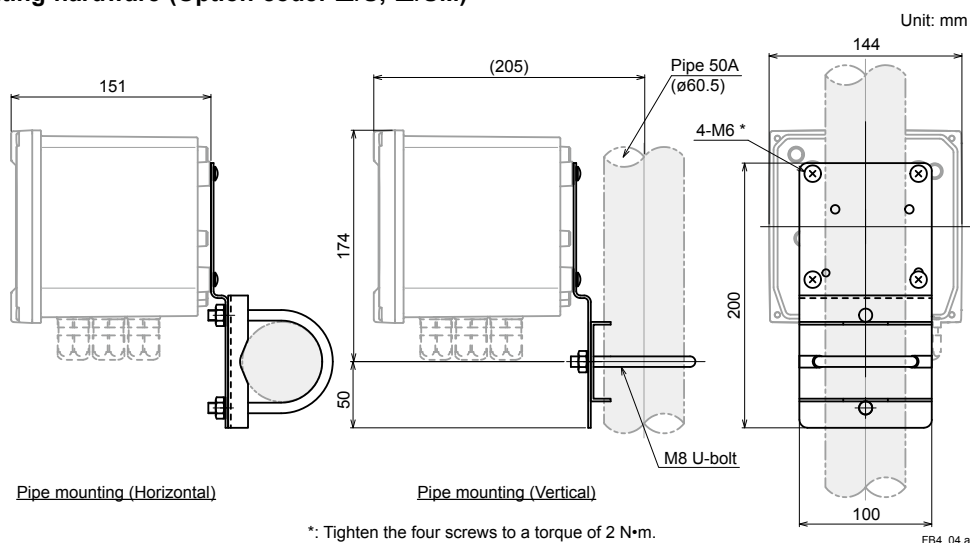

Stainless steel hood (Option code: □/H6, □/H7, □/H8)

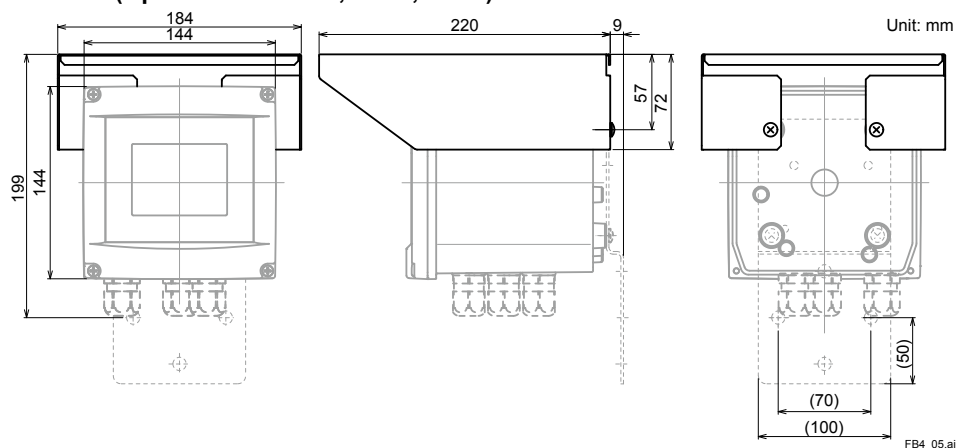

Stainless Steel Housing

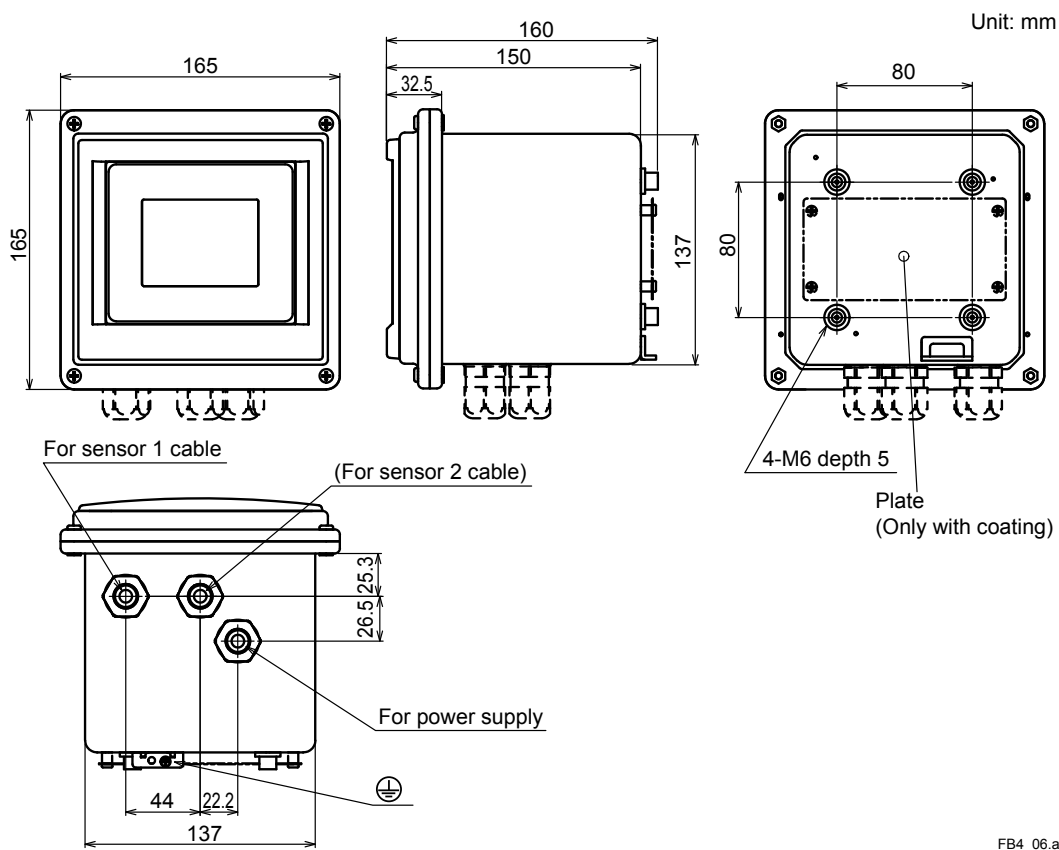

Conduit Adapter (Option code: □/CB4, □/CD4, □/CF4)

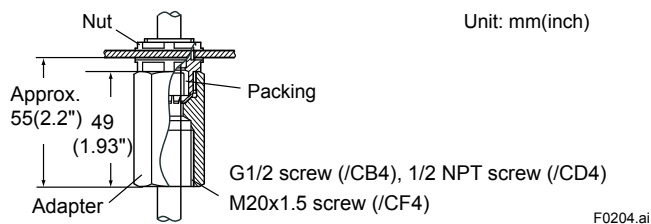

(Note) The universal mounting kit (/UM) contains the pipe and wall mounting hardware (/U) and the panel mounting hardware (/PM).

Panel mounting hardware (Option code: □/PM, □/UM)

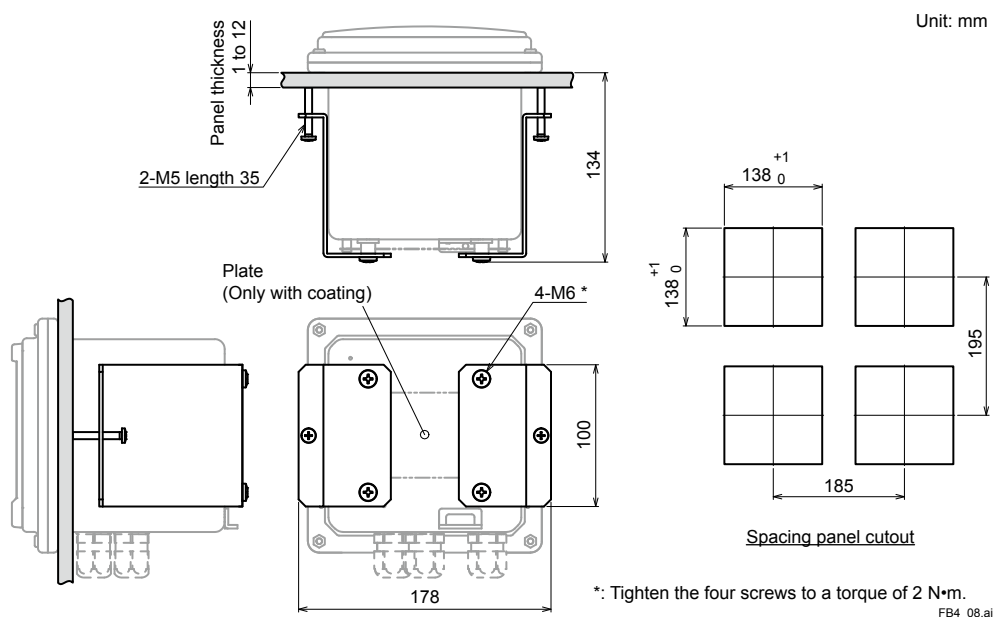

Wall mounting hardware (Option code: □/U, □/UM)

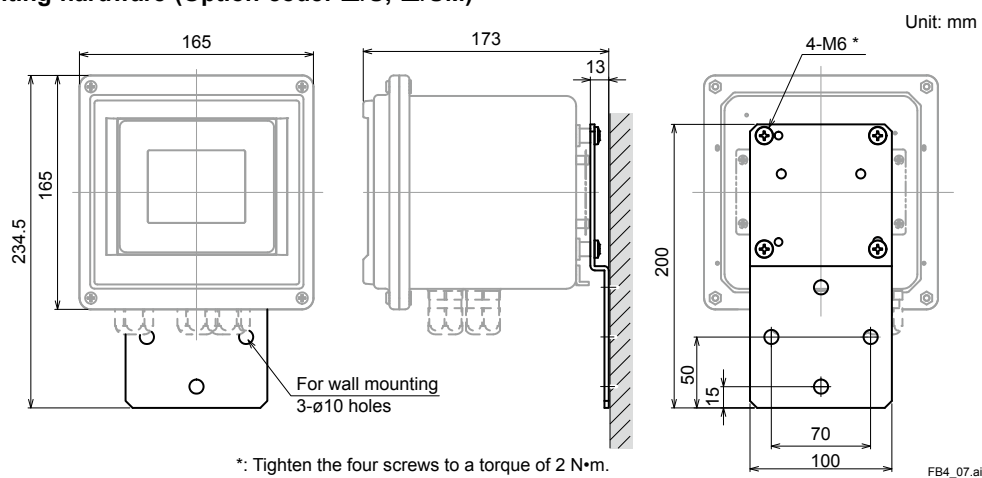

Note: The wall on which the analyzer is mounted should be strong enough to bear the weight of more than 8 kg.

Pipe mounting hardware (Option code: □/U, □/UM)

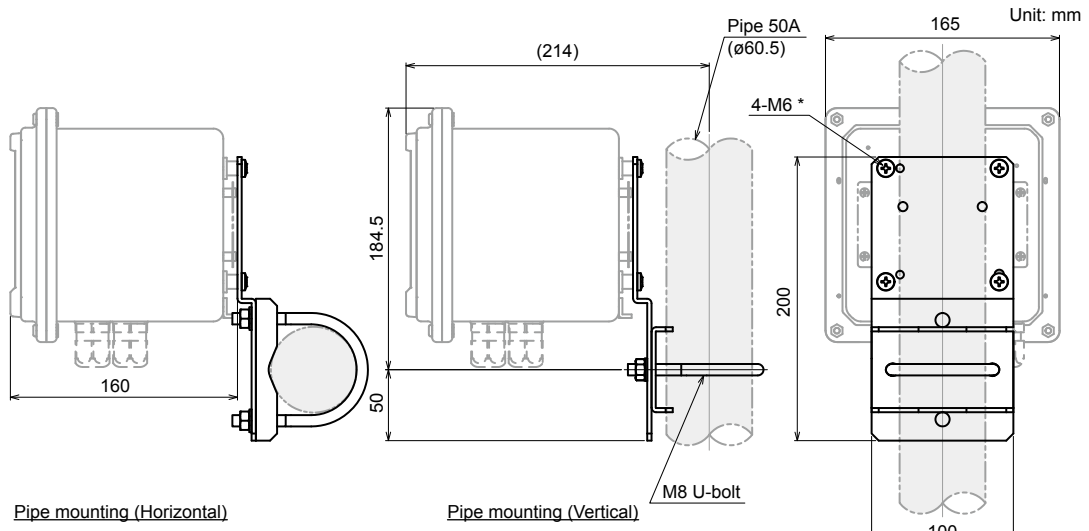

*: Tighten the four screws to a torque of 2 N•m.

FB4_09.ai

Stainless steel hood (Option code: □/H6, □/H7, □/H8)

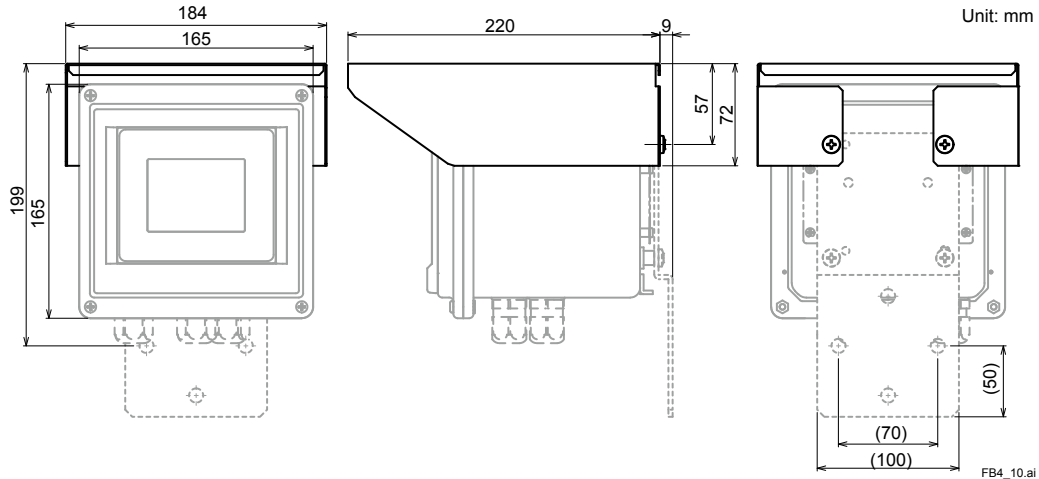

FB4_10.ai

■ Wiring Diagrams

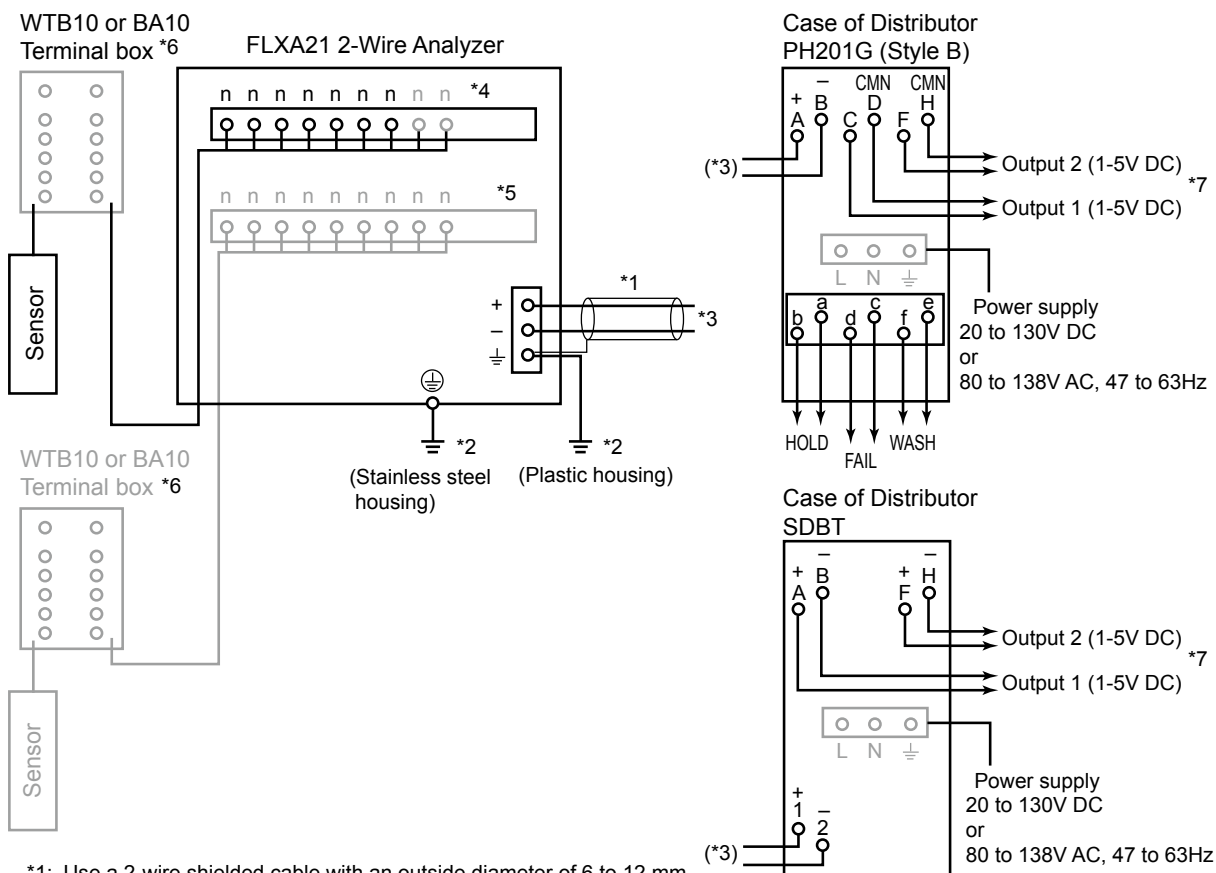

- *1: Use a 2-wire shielded cable with an outside diameter of 6 to 12 mm.
- *2: Connect the analyzer to ground. (Class D ground: 100 ohm or less)
The way of connecting the grounding cable varies depending on the plastic housing and stainless steel housing.
In the case of the plastic housing, connect the grounding cable to the \perp terminal of the power module inside, and in the case of the stainless steel housing, connect the grounding cable to the \oplus terminal of the housing. Use a cable with an outside diameter of 3.4 to 7 mm for the grounding line of the plastic housing. Although, on the stainless steel housing, the ground terminal symbol is \oplus (protective ground), the ground is really functional ground.
- *3: This line is connected to a distributor or 24V DC power supply.
- *4: Terminal numbers for each sensor module are shown below.
- *5: Two modules of the same kind of measurement/sensor type can be installed. When measuring inductive conductivity or pH/ORP with the SENCOM sensor, only one module can be installed.
- *6: The terminal box may be necessary depending on the sensor cable length and the distance between the analyzer and the sensor.
The SENCOM sensor is to be connected directly to the analyzer without a terminal box.
- *7: Two outputs, output 1 and output2, of PH201G or SDBT are same signals.

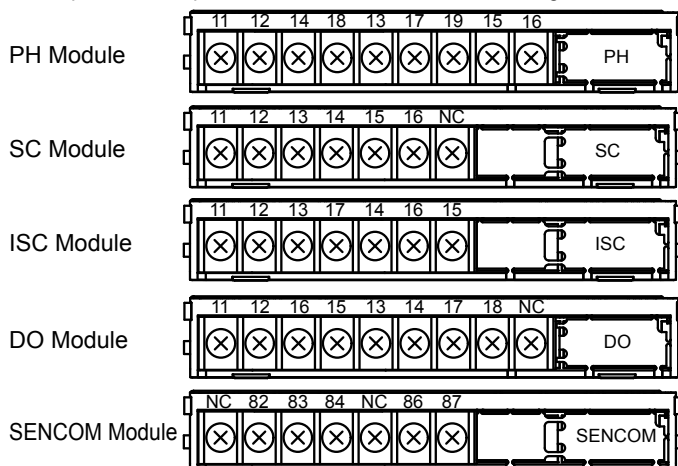

■ Inquiry Specifications Sheet for FLXA21 2-Wire Analyzer

Make inquiries by placing checkmarks (✓) in the pertinent boxes and filling in the blanks.

1. General Information

Company name _____
 Contact Person; _____ Department; _____
 Plant name; _____
 Measurement location; _____
 Purpose of use; Indication, Recording, Alarm, Control

2. Measurement Conditions

- (1) Process temperature; _____ to _____ Normally _____ [°C]
 (2) Process pressure; _____ to _____ Normally _____ [kPa]
 (3) Flow rate; _____ to _____ Normally _____ [l/min]
 (4) Flow speed; _____ to _____ Normally _____ [m/s]
 (5) Slurry or contaminants; No, Yes
 (6) Name of process fluid; _____
 (7) Components of process fluid; _____
 (8) Others;

3. Installation Site

- (1) Ambient temperature; _____ to _____ [°C]
 (2) Location; Outdoors, Indoors
 (3) Others;

4. Requirements

- 1st Input; pH/ORP (analog sensor) Conductivity (SC) Inductive conductivity (ISC)
 Dissolved oxygen (DO) pH/ORP (digital sensor, FU20F)
 2nd Input; With (same as 1st Input) Without

4.1 pH/ORP (analog sensor)

1st Input

- (1) Measuring range; pH 0 to 14 ORP _____ to _____ mV _____
 (2) Transmission output; 4 to 20 mA DC pH ORP Temperature
 (3) System configuration selection; Electrode, Holder, pH Converter, Cleaning system, Terminal box,
 Accessories
 (4) Electrode cable length; 3m, 5m, 7m, 10m, 15m, 20m, _____m
 (5) Electrode operating pressure; 10 kPa or less, More than 10 kPa
 (6) Type of holder; Guide pipe, Submersion, Flow-through, Suspension, Angled floating ball,
 Vertical floating ball
 (7) Cleaning method; No cleaning, Ultrasonic cleaning, Jet cleaning, Brush cleaning
 (8) Sample temperature; -5 to 105°C, -5 to 100°C, -5 to 80°C
 (9) Others;

2nd Input

- (1) Measuring range; pH 0 to 14 ORP _____ to _____ mV _____
 (2) Transmission output; 4 to 20 mA DC pH ORP Temperature
 (3) System configuration selection; Electrode, Holder, pH Converter, Cleaning system, Terminal box,
 Accessories
 (4) Electrode cable length; 3m, 5m, 7m, 10m, 15m, 20m, _____m
 (5) Electrode operating pressure; 10 kPa or less, More than 10 kPa
 (6) Type of holder; Guide pipe, Submersion, Flow-through, Suspension, Angled floating ball,
 Vertical floating ball
 (7) Cleaning method; No cleaning, Ultrasonic cleaning, Jet cleaning, Brush cleaning
 (8) Sample temperature; -5 to 105°C, -5 to 100°C, -5 to 80°C
 (9) Others;

4.2 Conductivity

1st Input

- (1) Measuring range; _____
- (2) Transmission output; 4 to 20 mA DC
- (3) Detector/sensor; SC4AJ Two electrode system (0.02 cm⁻¹) Two electrode system (0.1 cm⁻¹)
 SC8SG Two electrode system (0.01 cm⁻¹) Two electrode system (10 cm⁻¹),
 Four electrode system (10 cm⁻¹)
 SC210G Two electrode system (0.05 cm⁻¹) Two electrode system (5 cm⁻¹)
- (4) Detector/sensor mounting method;
 SC4AJ Adapter mounting, Welding socket, Welding clamp
 SC8SG Screw-in, Flow-through
 SC210G Screw-in, Flange, Flow-through, Screw-in with gate valve
- (5) Electrode cable length; SC4AJ 3m, 5m, 10m, 20m
 SC8SG 5.5m, 10m, 20m
 SC210G 3m, 5m, 10m, 15m, 20m
- (6) Others;

2nd Input

- (1) Measuring range; _____
- (2) Transmission output; 4 to 20 mA DC
- (3) Detector/sensor; SC4AJ Two electrode system (0.02 cm⁻¹) Two electrode system (0.1 cm⁻¹)
 SC8SG Two electrode system (0.01 cm⁻¹) Two electrode system (10 cm⁻¹),
 Four electrode system (10 cm⁻¹)
 SC210G Two electrode system (0.05 cm⁻¹) Two electrode system (5 cm⁻¹)
- (4) Detector/sensor mounting method;
 SC4AJ Adapter mounting, Welding socket, Welding clamp
 SC8SG Screw-in, Flow-through
 SC210G Screw-in, Flange, Flow-through, Screw-in with gate valve
- (5) Electrode cable length; SC4AJ 3m, 5m, 10m, 20m
 SC8SG 5.5m, 10m, 20m
 SC210G 3m, 5m, 10m, 15m, 20m
- (6) Others;

4.3 Inductive conductivity

- (1) Measuring range; _____
- (2) Transmission output; 4 to 20 mA DC
- (3) System configuration selection; ISC40GJ Sensor, Holder, Converter, BA20 Terminal box,
 WF10J Extension cable
- (4) Sensor mounting method; ISC40FDJ Immersion holder, ISC40FFJ Flow-through holder,
 ISC40FSJ Direct insertion adapter
- (5) ISC40GJ Sensor cable length; 5m, 10m, 15m, 20m
- (6) WF10J Extension cable length; 5m, 10m, 20m, 30m, 40m
- (7) Others;

4.4 Dissolved oxygen

1st Input

- (1) Measuring range; 0 to 50 mg/L _____
- (2) Transmission output; 4 to 20 mA DC
- (3) System configuration selection; Electrode, Holder, Converter, Cleaning system,
 Terminal box, Maintenance parts set, Calibration set
- (4) Electrode cable length; 3m, 5m, 10m, 15m, 20m
- (5) Type of holder; Guide pipe, Submersion, Flow-through, Suspension,
 Angled floating ball, Vertical floating ball
- (6) Cleaning method; No cleaning, Jet cleaning
- (7) Others;

2nd Input

- (1) Measuring range; 0 to 50 mg/L _____
- (2) Transmission output; 4 to 20 mA DC
- (3) System configuration selection; Electrode, Holder, Converter, Cleaning system,
 Terminal box, Maintenance parts set, Calibration set
- (4) Electrode cable length; 3m, 5m, 10m, 15m, 20m
- (5) Type of holder; Guide pipe, Submersion, Flow-through, Suspension,
 Angled floating ball, Vertical floating ball
- (6) Cleaning method; No cleaning, Jet cleaning
- (7) Others;

4.5 pH/ORP (digital sensor, FU20F)

- (1) Measuring range; pH 0 to 14 ORP _____ to _____ mV _____
- (2) Transmission output; 4 to 20 mA DC pH ORP Temperature
- (3) System configuration selection; Electrode, Holder, pH Converter, Cleaning system, Accessories
- (4) Electrode cable length; 3m, 5m, 10m, 20m, _____m
- (5) Electrode operating pressure; 10 kPa or less, More than 10 kPa
- (6) Type of holder; Guide pipe, Submersion, Flow-through, Suspension, Angled floating ball,
 Vertical floating ball
- (7) Cleaning method; No cleaning, Jet cleaning
- (8) Sample temperature; -5 to 105°C, -5 to 100°C, -5 to 80°C
- (9) Others;